

# A900 Automatic Control Valve

The A900 series of automatic control valves are Basic Valves to provide hydraulically driven solutions to pressure, flow and level control applications.

## Features:

- Top and seat ring guided stem and diaphragm assembly for long life and reliability.
- All iron components are fusion epoxy bonded for corrosion resistance.
- Easy maintenance without removal from the main line.
- Nylon reinforced diaphragm for long term service.
- Drip tight shut off.
- Globe design for superior control characteristics.
- Ductile iron bodies for higher strength and durability.
- Corrosion resistant stainless steel seat and disc retainer ring.
- Various pilots and accessories available for configuration into many different applications.
- Special V-Port and double chamber are options, please consult factory.
- Meet standards BS EN 1074-5, ISO 5208, BS EN 12266-1, BS EN 558-1,

## General Application:

For pressure, flow and level control in water applications.

## Technical Data:

Size Range: DN50~DN900mm Pressure Ratings: 1.0Mpa; 1.6Mpa; 2.5Mpa Working Temperature:-10°C- 80°C Suitable Media: Water End connection: PN 10/ PN 16/ PN 25 Consult Factory for other applications



# A900-Main Valve DN50-DN350

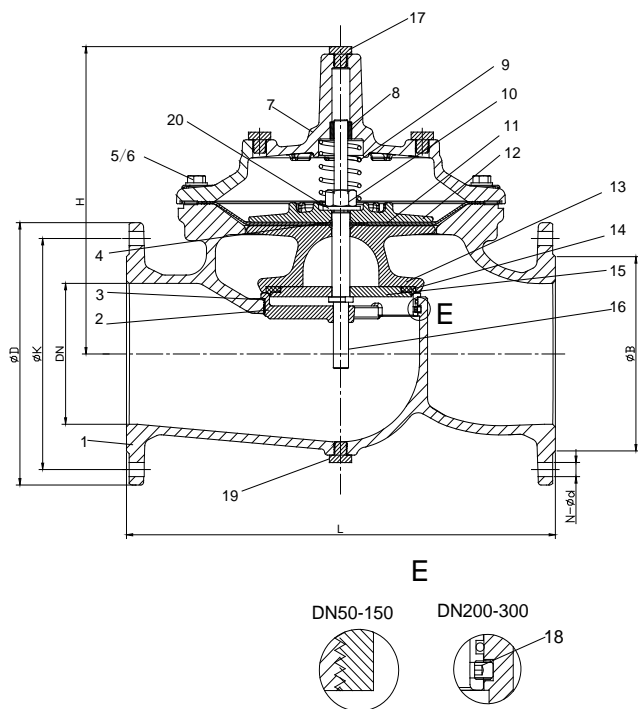

## Parts List

No.	Description	Material	Standard
1	Body	Ductlie Iron	GJS 500-7
2	Seat	Stainless Steel	AISI 304/316
3	O-ring	Rubber	NBR
4	O-ring	Rubber	NBR
5	Bolt	Stainless Steel	A2/A4
6	Washer	Stainless Steel	A2/A4
7	Bonnet	Ductlie Iron	GJS 500-7
8	Bush	Bronze	C61900
9	Spring	Stainless Steel	AISI 304/316
10	Caulking Nut	Stainless Steel	A4
11	Diaphragm	Nylon Reinforced Rubber	EPDM +Nylon Fabric
12	Fixing holder	Ductlie Iron	GJS 500-7
13	Disc Holder	Ductlie Iron	GJS 500-7
14	Seal	Rubber	EPDM
15	Seat Retainer	Stainless Steel	AISI 304/316
16	Stem	Stainless Steel	AISI 304/316
17	Plug	Stainless Steel	AISI 304/316
18	Screw	Stainless Steel	A2/A4
19	Plug	Stainless Steel	A2/A4
20	Washer	Stainless Steel	A2/A4

## Dimension:

DN	Model Code	L	ØD			ØK			H	N-Ød			ØB		
			PN10	PN16	PN25	PN10	PN16	PN25		PN10	PN16	PN25	PN10	PN16	PN25
50	A900-0050	230	165	165	165	125	125	125	177	4-Ø19	4-Ø19	4-Ø19	Ø99	Ø99	Ø99
65	A900-0065	290	185	185	185	145	145	145	202	4-Ø19	4-Ø19	8-Ø19	Ø118	Ø118	Ø118
80	A900-0080	310	200	200	200	160	160	160	219	8-Ø19	8-Ø19	8-Ø19	Ø132	Ø132	Ø132
100	A900-0100	350	220	220	235	180	180	190	243	8-Ø19	8-Ø19	8-Ø23	Ø156	Ø156	Ø156
*125	A900-0125	400	250	250	270	210	210	220	243	8-Ø19	8-Ø19	8-Ø28	Ø156	Ø156	Ø156
150	A900-0150	480	285	285	300	240	240	250	333	8-Ø23	8-Ø23	8-Ø28	Ø211	Ø211	Ø211
200	A900-0200	600	340	340	360	295	295	310	428	8-Ø23	12-Ø23	12-Ø28	Ø266	Ø266	Ø274
250	A900-0250	730	405	405	425	350	355	370	478	12-Ø23	12-Ø28	12-Ø31	Ø319	Ø319	Ø330
300	A900-0300	850	460	460	485	400	410	430	538	12-Ø23	12-Ø28	16-Ø31	Ø370	Ø370	Ø389
*350	A900-0350	980	520	520	555	460	470	490	550	16-Ø23	16-Ø28	16-Ø34	Ø429	Ø429	Ø448

NOTE: 1. \*DN125/350 use same internal as DN100/300  
2. AISI 304 factory standard material. consult factory for AISI 316 material.

# A900-Main Valve DN400-DN800

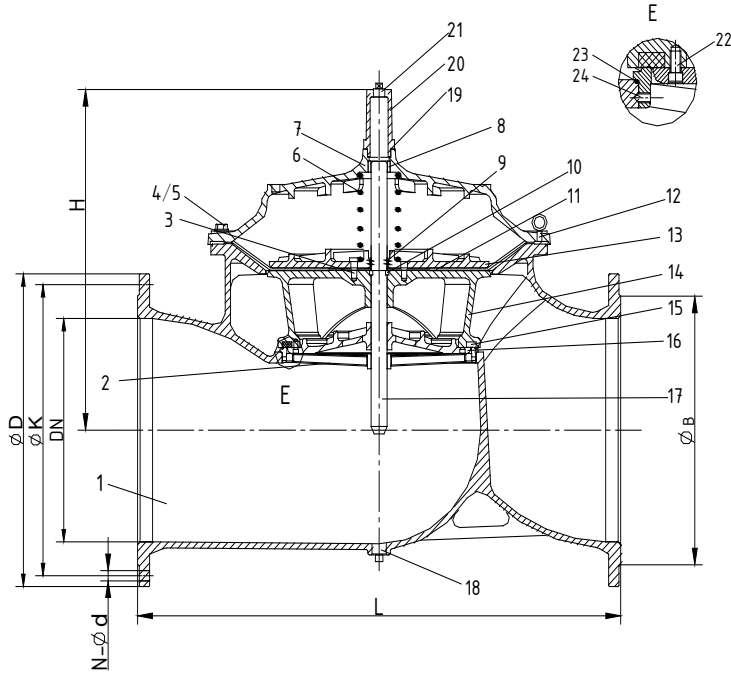

## Parts List

No.	Description	Material	Standard
1	Body	Ductile Iron	GJS 500-7
2	Seat	Stainless Steel	AISI 304/316
3	Screw	Stainless Steel	A2/A4
4	Screw	Stainless Steel	A2/A4
5	Screw	Stainless Steel	A2/A4
6	Spring	Stainless Steel	AISI 304/316
7	Bonnet	Ductile Iron	GJS 500-7
8	Bush	Bronze	C61900
9	O-ring	Rubber	NBR
10	Fix Washer	Bronze	C61900
11	Diaphragm	Nylon Reinforced Rubber	EPDM +Nylon Fabric
12	Eye Bolts	Carbon Steel	1040
13	Fixing Holder	Ductile Iron	GJS 500-7
14	Disc Holder	Ductile Iron	GJS 500-7
15	Seal	Rubber	EPDM
16	Seal Retainer	Ductile Iron	GJS 500-7
17	Stem	Stainless Steel	AISI 304/316
18	Plug	Stainless Steel	AISI 304/316
19	O-ring	Rubber	NBR
20	Cap	Ductile Iron	GJS 500-7
21	Plug	Stainless Steel	AISI 304/316
22	Screw	Stainless Steel	A2/A4
23	O-ring	Rubber	NBR
24	Screw	Stainless Steel	A2/A4

## Dimension:

Unit: mm

DN	Model Code	L	H	ØD			ØK			N-Ød			ØB		
				PN10	PN16	PN25	PN10	PN16	PN25	PN10	PN16	PN25	PN10	PN16	PN25
400	A900-0400	1100	710	580	580	620	515	525	550	16-Ø28	16-Ø31	16-Ø37	480	480	503
*450	A900-0450	1200	720	640	640	670	565	585	600	20-Ø28	20-Ø31	20-Ø37	530	548	548
500	A900-0500	1250	822	715	715	730	620	650	660	20-Ø28	20-Ø34	20-Ø37	582	609	609
600	A900-0600	1450	885	840	840	845	725	770	770	20-Ø31	20-Ø37	20-Ø40	682	720	720
700	A900-0700	1650	910	910	910	960	840	840	875	24-Ø31	24-Ø37	24-Ø43	682	720	720
800	A900-0800	1850	1260	1025	1025	1085	950	950	990	24-Ø34	24-Ø40	24-Ø49	901	901	928
900	A900-0900	1980	1650	1125	1125		1050	1050		28-Ø34	28-Ø40		1001	1001	

## P100-Float Pilot

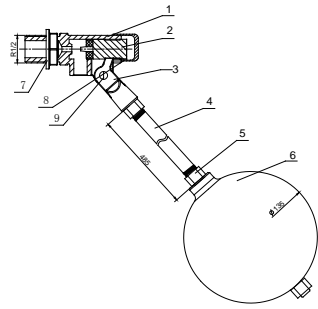

### Part List & Material

No.	Part Name	Material	Standard
1	Body	Stainless Steel	AISI 304
2	Disc	Stainless Steel+Rubber	AISI 304+EPDM
3	Yoke	Stainless Steel	AISI 304
4	Rod	Stainless Steel	AISI 304
5	Nut	Stainless Steel	AISI 304
6	Float	Stainless Steel	AISI 304
7	Jam Nut	Stainless Steel	A2
8	Bonnet	Stainless Steel	A2
9	Screw	Stainless Steel	A2

## P20A Anticipation Pilot (Preaction)

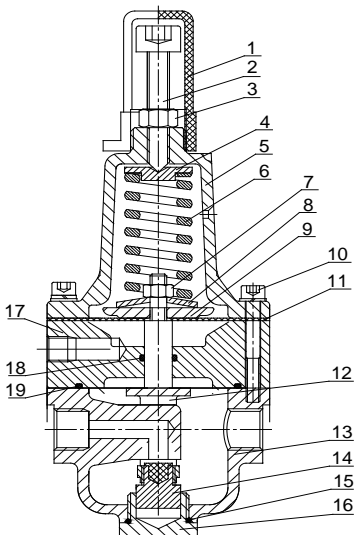

### Part list & Material

No.	Description	Material	Standard
1	Cap	Plastic	ABS
2	Adjusting Screw	Stainless Steel	AISI 304
3	Jam Nut	Stainless Steel	A2
4	Spring table	Stainless Steel	AISI 304
5	Bonnet	Stainless Steel	AISI 304
6	Spring	Spring Steel	SiCrV
7	Nut	Stainless Steel	A2
8	Spring table	Spring Steel	Mn-steel+Ni Plated
9	Fixing Holder	Stainless Steel	AISI 304
10	Screw	Stainless Steel	A2
11	Diaphragm	Rubber	NBR+Nylon
12	Yoke	Stainless Steel	AISI 304
13	Body	Stainless Steel	AISI 304
14	Disc	Stainless Steel+Rubber	AISI 304+EPDM
15	O-Ring	Rubber	NBR
16	Plug	Stainless Steel	AISI 304
17	Internal Body	Stainless Steel	AISI 304
18	O-Ring	Rubber	NBR
19	O-Ring	Rubber	NBR

# P10B Bi-Level float pilot

## Part list & Material

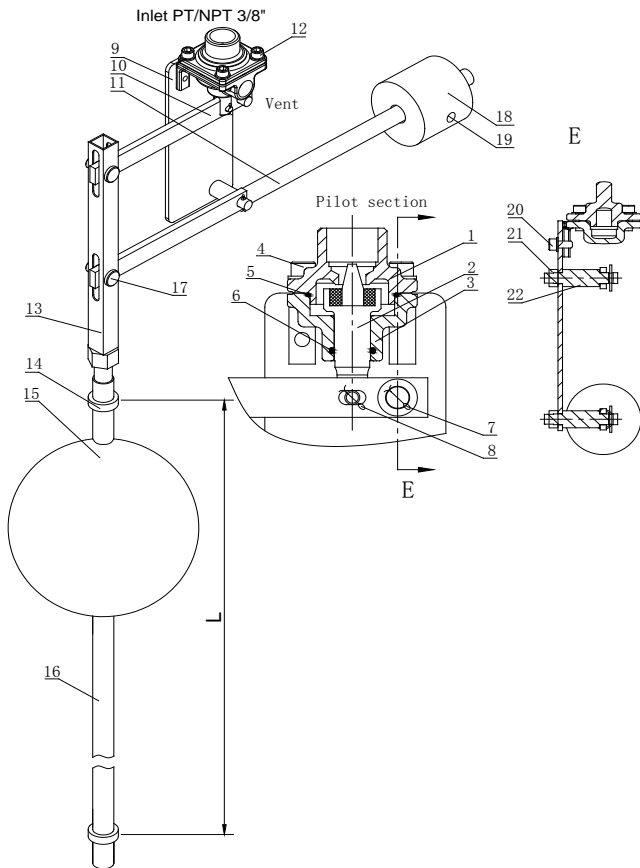

No.	Description	Material	Standard
1	Bonnet	Stainless Steel	AISI 304
2	Disc	Stainless Steel+Rubber	AISI 304+EPDM
3	Body	Stainless Steel	AISI 304
4	Bolt+Washer	Stainless Steel	A2
5	O-Ring	Rubber	NBR
6	O-Ring	Rubber	NBR
7	Split pin	Stainless Steel	A2
8	Split pin	Stainless Steel	A2
9	Plate	Stainless Steel	AISI 304
10	Bar1	Stainless Steel	AISI 304
11	Bar2	Stainless Steel	AISI 304
12	Screw	Stainless Steel	AISI 304
13	Up Rod	Stainless Steel	AISI 304
14	Stop collar	Stainless Steel	AISI 304
15	Float	Stainless Steel	AISI 304
16	Low rod	Stainless Steel	AISI 304
17	Pin roll & split pin	Stainless Steel	A2
18	Weight	Stainless Steel	AISI 304
19	Set Screw	Stainless Steel	A2
20	Nut+Washer	Stainless Steel	A2
21	Nut	Stainless Steel	A2
22	Roller	Stainless Steel	AISI 304

# P10A Altitude pilot

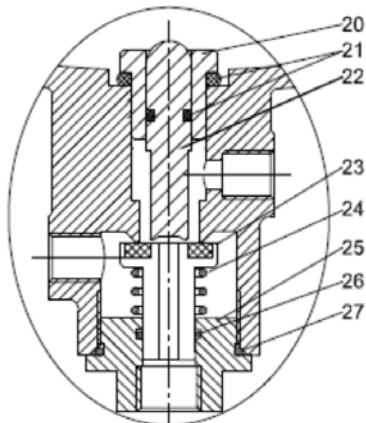
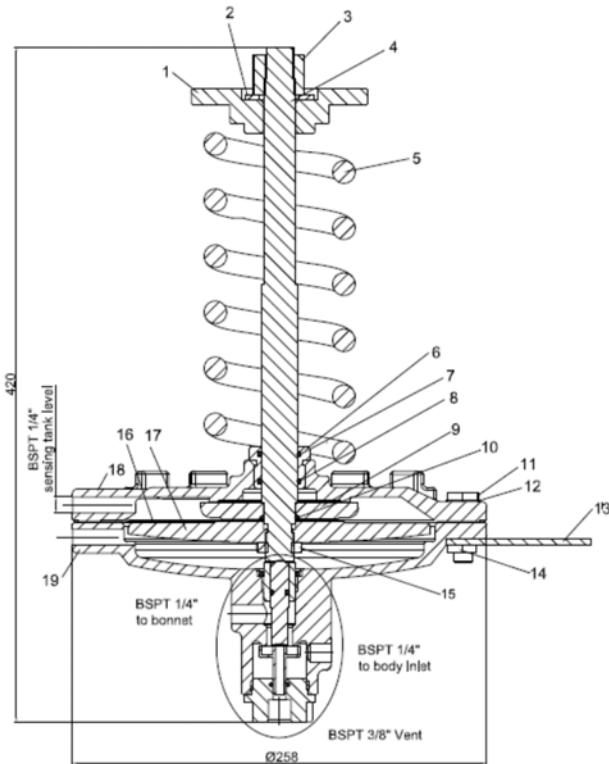

## Part list & Material

No.	Description	Material	Standard
1	Pressure plate	Stainless Steel	AISI 304
2	Washer	Stainless Steel	AISI 304
3	Adjusting Nut	Brass	CZ122
4	Upper stem	Stainless Steel	AISI 304
5	Spring	Spring Steel	Mn-steel+Ni
6	Bush	Brass	CZ122
7	O-Ring	Rubber	NBR
8	O-Ring	Rubber	NBR
9	Fixing holder	Stainless Steel	AISI 304
10	O-Ring	Rubber	NBR
11	Diaphragm	Nylon Reinforced Rubber	EPDM+Nylon
12	Diaphragm retainer	Stainless Steel	AISI 304
13	Connecting plate	Stainless Steel	AISI 304
14	Stem nut	Stainless Steel	AISI 304
15	Screw	Stainless Steel	AISI 304
16	Washer	Stainless Steel	AISI 304
17	Bonnet	Stainless Steel	AISI 304
18	Body	Stainless Steel	AISI 304
19	Nut	Stainless Steel	AISI 304
20	Nut	Brass	CZ122
21	O-Ring	Rubber	NBR
22	Shaft	Stainless Steel	AISI 304
23	Disc	Stainless Steel+Rubber	A304+EPDM
24	Spring	Stainless Steel	AISI 304
25	Plug	Brass	CZ122
26	O-Ring	Rubber	NBR
27	O-Ring	Rubber	NBR

## P200-Reducing Pilot

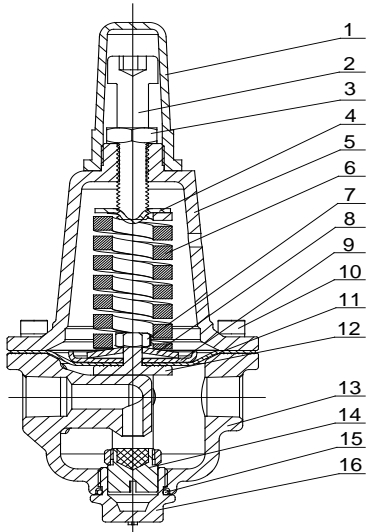

### Part list & Material

No.	Description	Material	Standard
1	Cap	Plastic	ABS
2	Adjusting Screw	Stainless Steel	AISI 304
3	Jam Nut	Stainless Steel	A2
4	Spring table	Stainless Steel	AISI 304
5	Bonnet	Stainless Steel	AISI 304
6	Spring	Spring Steel	SiCrV
7	Nut	Stainless Steel	A2
8	Spring table	Spring Steel	Mn-steel+Ni Plated
9	Fixing Holder	Stainless Steel	AISI 304
10	Screw	Stainless Steel	A2
11	Diaphragm	Nylon Reinforced Rubber	EPDM+Nylon
12	Yoke	Stainless Steel	AISI 304
13	Body	Stainless Steel	AISI 304
14	Disc	Stainless Steel+Rubber	AISI 304+EPDM
15	O-Ring	Rubber	NBR
16	Plug	Stainless Steel	AISI 304

## P500-Relief/Sustaining Pilot

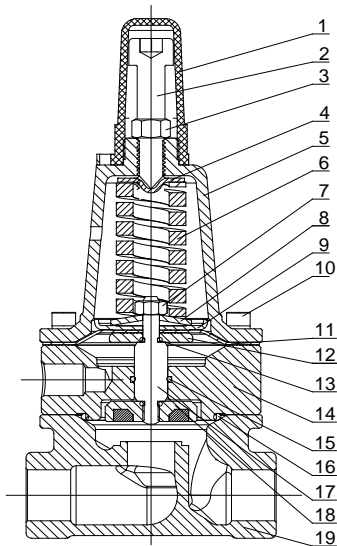

### Part list & Material

No.	Description	Material	Standard
1	Cap	Plastic	ABS
2	Adjusting Screw	Stainless Steel	AISI 304
3	Jam Nut	Stainless Steel	AISI 304
4	Spring table	Stainless Steel	AISI 304
5	Bonnet	Stainless Steel	AISI 304
6	Spring	Spring Steel	SiCrV
7	Nut	Stainless Steel	A2
8	Spring table	Spring Steel	Mn-steel+Ni Plated
9	Fixing Holder	Stainless Steel	AISI 304
10	Screw	Stainless Steel	A2
11	Diaphragm	Nylon Reinforced Rubber	EPDM+Nylon
12	Gasket	Stainless Steel	AISI 304
13	O-Ring	Rubber	NBR
14	Internal Body	Stainless Steel	AISI 304
15	O-Ring	Rubber	NBR
16	O-Ring	Rubber	NBR
17	Stem	Stainless Steel	AISI 304
18	Disc	Stainless Steel+Rubber	AISI 304+EPDM
19	Body	Stainless Steel	AISI 304

## P400 Flow rate control Pilot

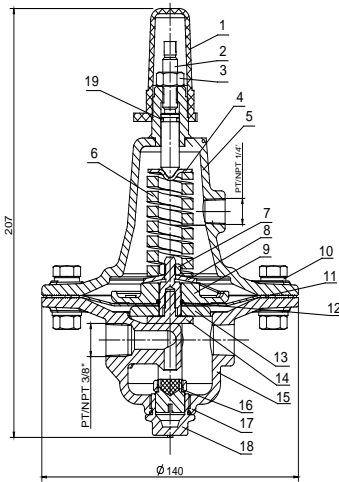

### Part list & Material

No.	Description	Material	Standard
1	Cap	Plastic	ABS
2	Adjusting Screw	Stainless Steel	AISI 304
3	Jam Nut	Stainless Steel	AISI 304
4	Spring table	Stainless Steel	AISI 304
5	Bonnet	Stainless Steel	AISI 304
6	Spring	Spring Steel	SiCrV
7	Nut	Stainless Steel	A2
8	Spring table	Spring Steel	Mn-steel+Ni Plated
9	Fixing Holder	Stainless Steel	AISI 304
10	Screw	Stainless Steel	A2
11	Diaphragm	Nylon Reinforced Rubber	EPDM+Nylon
12	O-Ring	Rubber	NBR
13	Gasket	Stainless Steel	AISI 304
14	Stem	Stainless Steel	AISI 304
15	Body	Stainless Steel	AISI 304
16	Disc	Stainless Steel+Rubber	AISI 304+EPDM
17	O-Ring	Rubber	NBR
18	Plug	Stainless Steel	AISI 304
19	O-Ring	Rubber	NBR

## P800 Differential pressure pilot

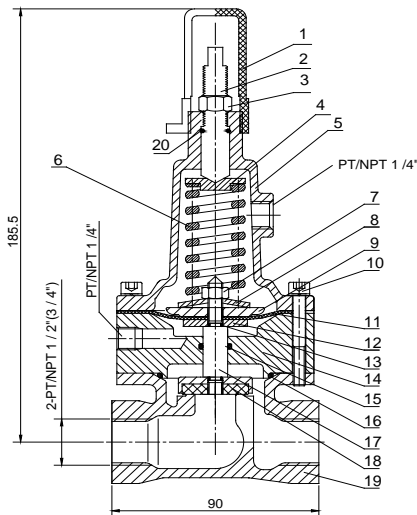

### Part list & Material

No.	Description	Material	Standard
1	Cap	Plastic	ABS
2	Adjusting Screw	Stainless Steel	AISI 304
3	Jam Nut	Stainless Steel	AISI 304
4	Spring table	Stainless Steel	AISI 304
5	Bonnet	Stainless Steel	AISI 304
6	Spring	Spring Steel	SiCrV
7	Nut	Stainless Steel	A2
8	Spring table	Spring Steel	Mn-steel+Ni Plated
9	Fixing Holder	Stainless Steel	AISI 304
10	Screw	Stainless Steel	A2
11	Diaphragm	Nylon Reinforced Rubber	EPDM+Nylon
12	Gasket	Stainless Steel	AISI 304
13	O-Ring	Rubber	NBR
14	Internal Body	Stainless Steel	AISI 304
15	O-Ring	Rubber	NBR
16	O-Ring	Rubber	NBR
17	Stem	Stainless Steel	AISI 304
18	Disc	Stainless Steel+Rubber	AISI 304+EPDM
19	Body	Stainless Steel	AISI 304
20	O-Ring	Rubber	NBR



## A100 Remote Float Control Valve

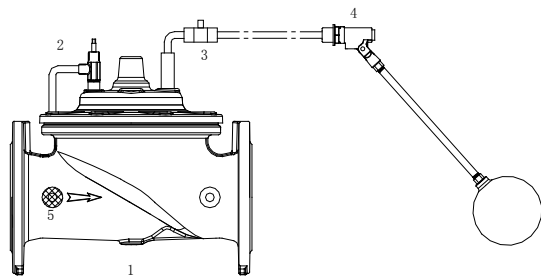

1. Main Valve
2. Needle Valve
3. Ball Valve
4. P100
5. Strainer

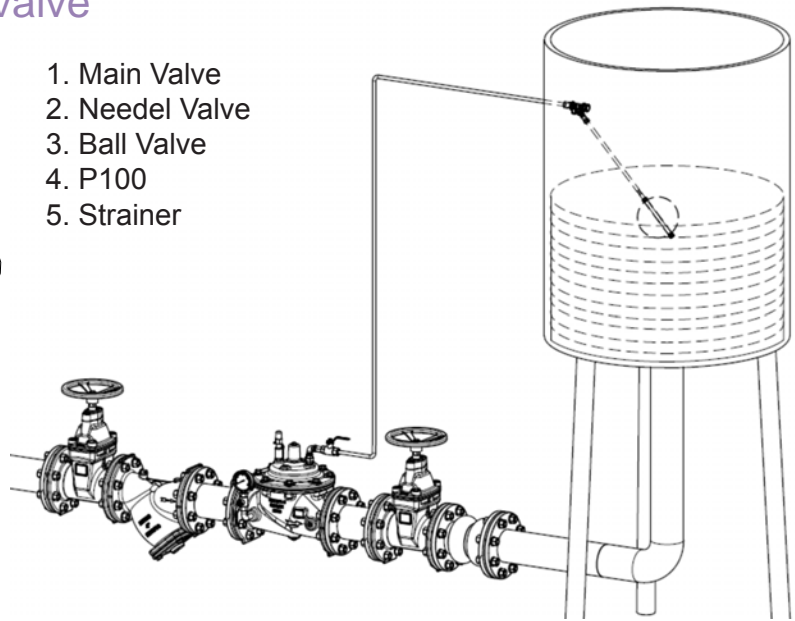

### Function:

1. When water level reaches high water level, the float pilot will shut off and close the main valve.
2. Whenever the water level drops, the float pilot starts to open and main valve opens.

## A200 Pressure Reducing Valve

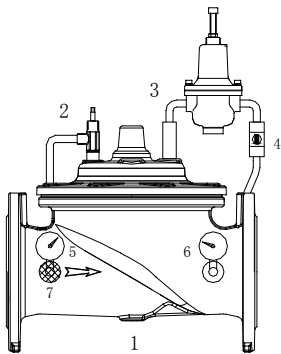

1. Main Valve
2. Needle Valve
3. P200
4. Ball Valve
5. Inlet Pressure Gauge(Optional)
6. Outlet Pressure Gauge(Optional)
7. Strainer

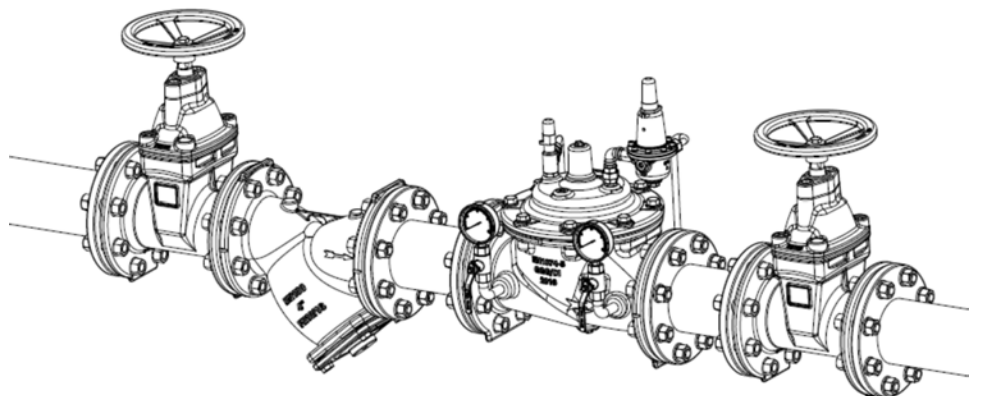

### Function:

1. Will reduce the higher upstream pressure and keep the downstream pressure as the pilot setting (adjustable).
2. Regardless of variation of upstream pressure or downstream flow.

## A205 Pressure Sustaining/Reducing Valve

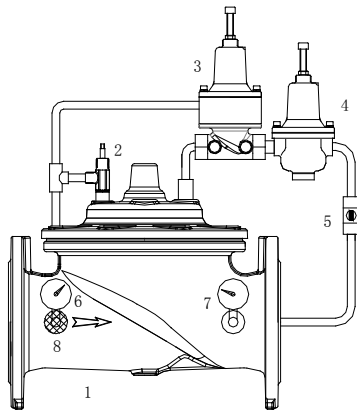

1. Main Valve
2. Needle Valve
3. P500
4. P200
5. Ball Valve
6. Inlet Pressure Gauge(Optional)
7. Outlet Pressure Gauge(Optional)
8. Strainer

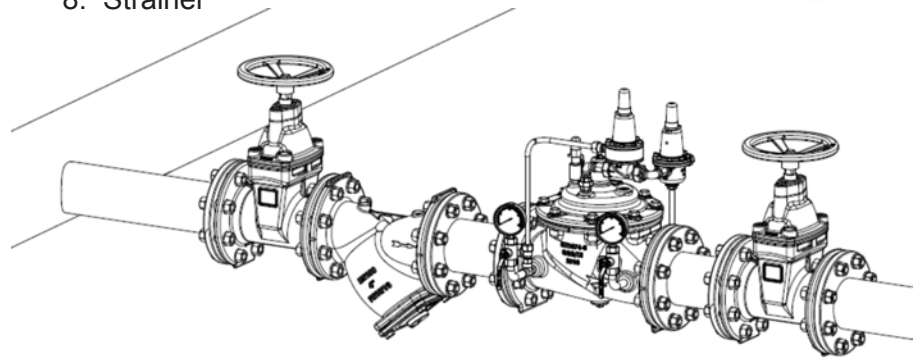

### Function:

1. The sustaining pilot keeps the upstream pressure above the pilot setting regardless of downstream flow.
2. Will reduce the higher upstream pressure and keep the downstream pressure as the pilot setting (adjustable).
3. Regardless of variation of upstream pressure or downstream flow.

## A2A5 Surge Anticipation Valve

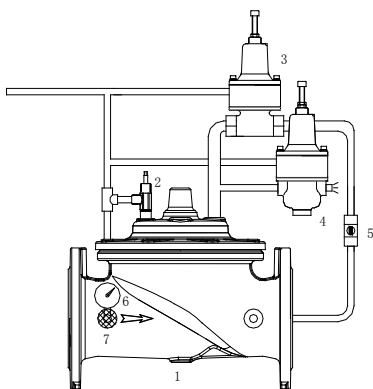

1. Main Valve
2. Needle Valve
3. P500
4. P20A
5. Ball Valve
6. Inlet Pressure Gauge (Optional)
7. Strainer

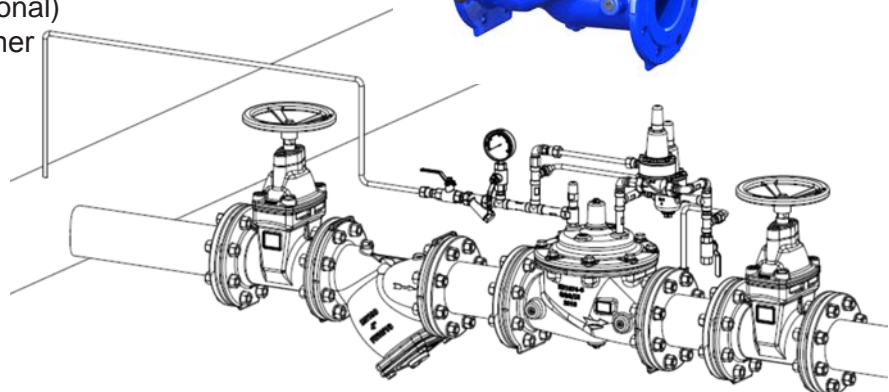

### Function:

1. P20A is used for sensing to open at low pressure before surge, for quick relief high pressure wave.
2. The pre-open function eliminates the surge during pump abrupt stoppage.
3. The valve releases excessive system pressure.

## A300-Slow Control Check Valve

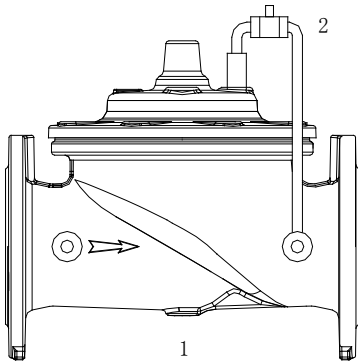

1. Main Valve
2. Ball Valve

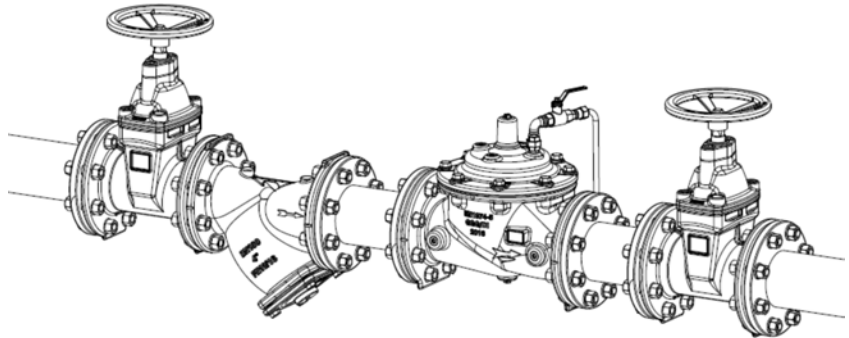

### Function:

Function as the check valve, and can be speed controlled.

## A400-Flow Control Valve

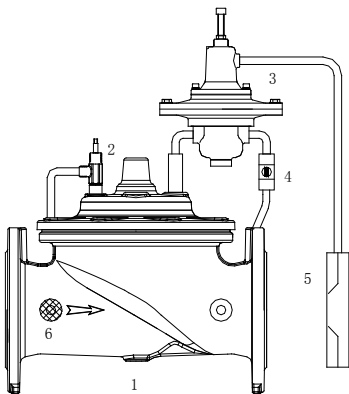

1. Main Valve
2. Needle Valve
3. P400
4. Ball Valve
5. Orifice Kit
6. Strainer

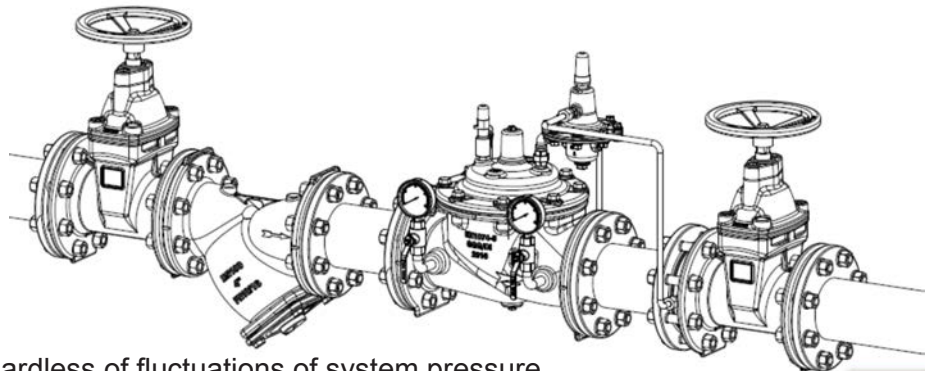

### Function:

1. Maintains a constant flow, regardless of fluctuations of system pressure.
2. The rate of flow pilot can be adjustable, and senses the pressure differential across an orifice plate mounted in the valve outlet flange.
3. Whenever the system pressure changes, the flow pilot responds and modulate the main valve to maintain the desired flow.

## A500 Pressure Relief/Sustaining Valve

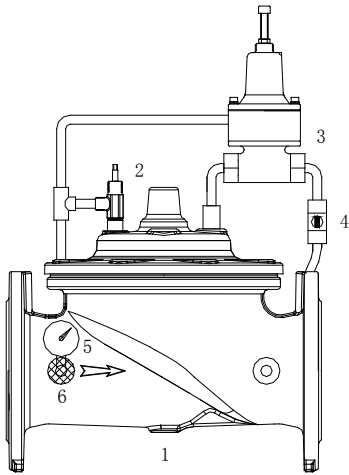

1. Main Valve
2. Needle Valve
3. P500
4. Ball Valve
5. Inlet Pressure Gauge (Optional)
6. Strainer

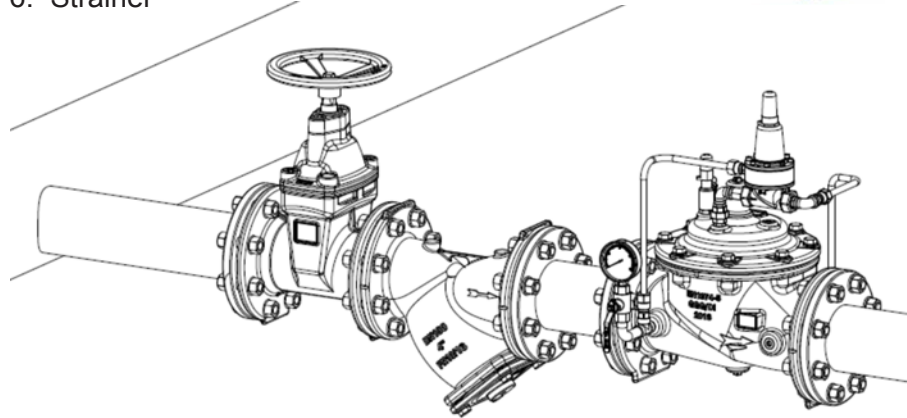

### Function:

1. Relief: whenever the system pressure exceeds the preset of pilot, the valve will immediately open to release excess pressure. And keep the system in a safety environment.
2. Sustaining: prevents upstream pressure (mainline) from dropping below the preset pressure.

## A600-Solenoid Control Valve

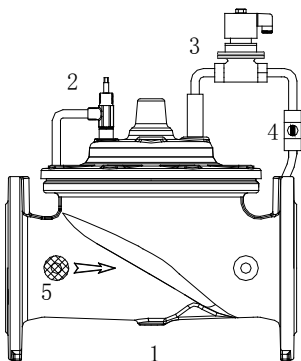

1. Main Valve
2. Needle Valve
3. Solenoid Valve
4. Ball Valve
5. Strainer

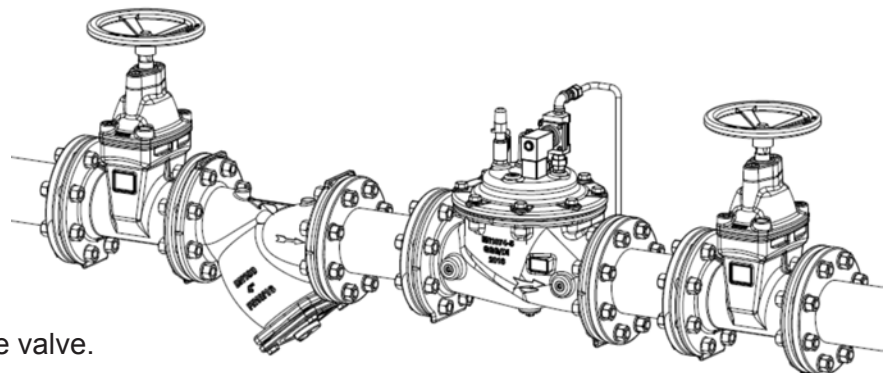

### Function:

1. 2-way solenoid-energized to open the valve.
2. 2-way solenoid-de-energized to close the valve.
3. 4-way solenoid for special service conditions can be consulted.

## A800-Pressure Differential Valve

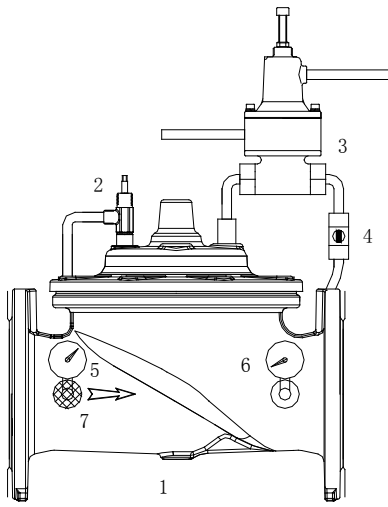

1. Main Valve
2. Needle Valve
3. P800
4. Ball Valve
5. Inlet Pressure Gauge (Optional)
6. Outlet Pressure Gauge (Optional)
7. Strainer

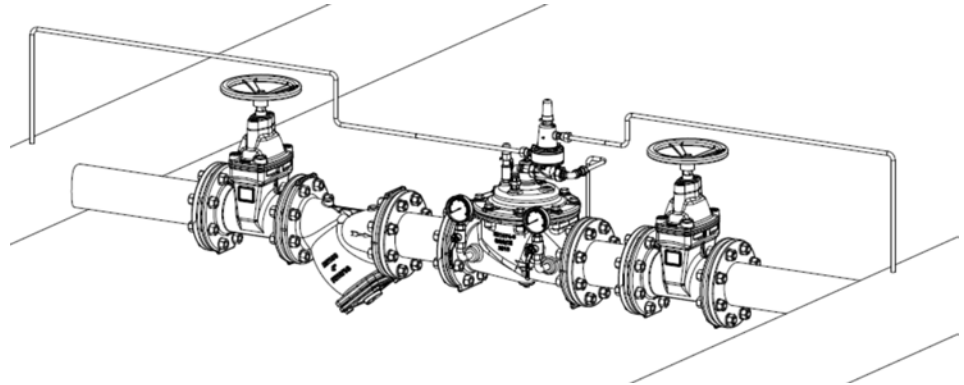

### Function:

The main valve will open against the system pressure differential whenever exceeds the pilot setting. (adjustable).

## Head Loss Curve

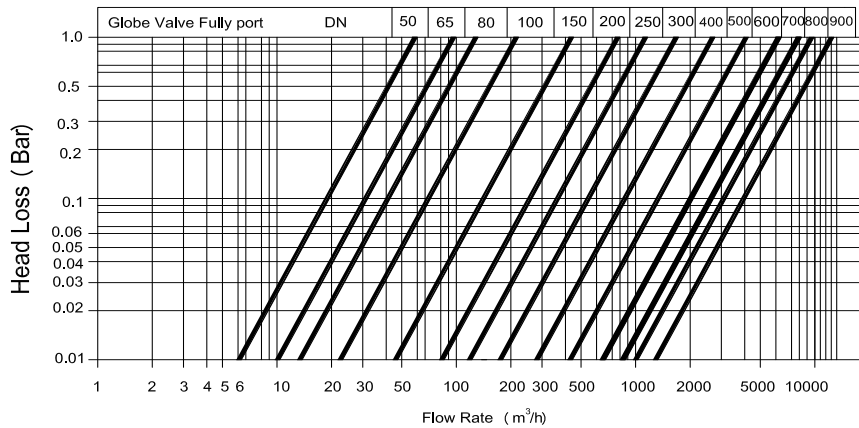

## Cavitation

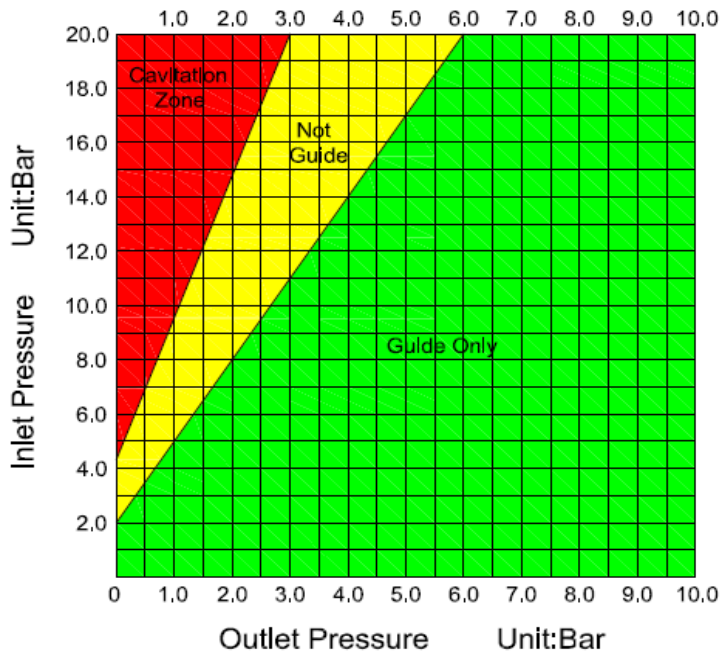

## Ordering Code

AXXX-0200-16-YYY

### Model:

- A100: Remote Float Valve
- A200: Pressure Reducing Valve
- A300: Slow Control Check Valve
- A400: Flow Control Valve
- A500: Pressure Relief/Sustaining Valve
- A600: Solenoid Control Valve
- A70D: Pump Control Valve
- A800: Pressure Differential Valve
- A900: Main Valve

YYY: Special Code  
Please Consult Factory

### Pressure Rating:

- 10: PN10
- 16: PN16
- 25: PN25
- A1: ANSI 125 F/F
- A5: ANSI 150 R/F

### Size:

- 0080: 80 mm
- 0200: 200 mm

TEL: +603 5167 2818,  
FAX: +603 5167 2817

AFC Valves Malaysia Sdn Bhd  
Add: NO. 6, JALAN SUNGAI JELUH 32/189,  
BUKIT NAGA INDUSTRIAL PARK,  
SEKSYEN 32, 40460,  
SELANGOR D. E. MALAYSIA.

